

MOULDINGS | STEEL MOULDING - SOUND RETARDANT

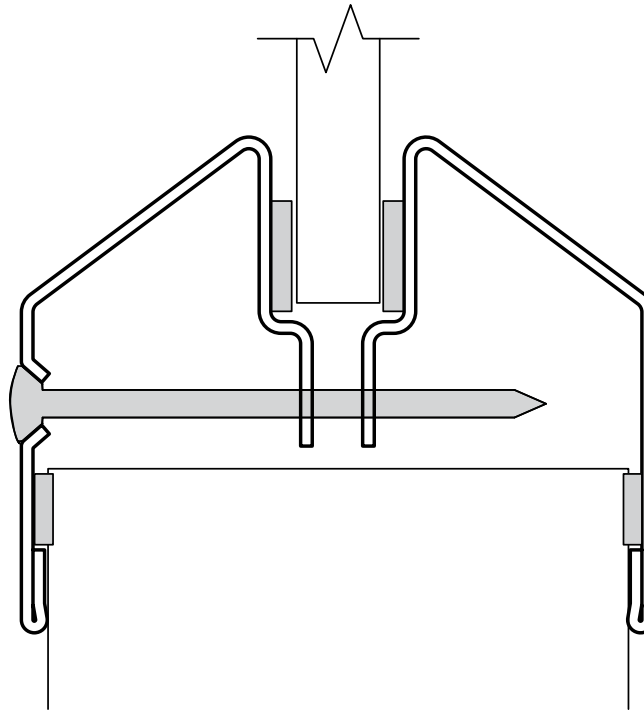

PEMKO LTB1-2-3
IN STOCK 5" X 20", LTB1 MODEL.



STEEL MOULDING

Core components come pre-measured to standard sizes that vary depending on door size and intended use.

Standard sizes are suitable for the following door sizes: 3'0" x 7'0", 3'6" x 7'0", and 3'0" x 8'0". Custom sizes available on request.

The face must be glued to the core in accordance with industry standards for 1 3/4" 5-ply flush doors.

Sanding of the face is acceptable; however, a minimum door thickness of 1 1/2" must be maintained.

Specifications are based on a 3'0" x 7'0" test door.

All STC tests are carried out with a specific sound-rating hardware configuration.

Extra heavy duty hinges are recommended.

Some hatches have been tested and can affect STC performance. Contact us for any construction modification or required hatches.

Any hardware not installed using through bolts must be properly tightened.

All levels of STC performance require specific sealing products and procedures.

We supply sealing products with door assembly. Upon request, sealing products can be purchased at your convenience from a tested and approved manufacturer.

Please refer to installation specifications for sealants.

Sealant must be adjusted to door thickness and width according to manufacturer's specifications and third party testing.