

WOOD VENEER SELECTION

(Reference : © 2009, AWI, AWMAC, WI - AWS - 1st Edition, October 1, 2009 and WDMA 1.S.1A-04)

APPEARANCE OF INDIVIDUAL VENEER SHEETS

Faces will have the natural variations in grain inherent to the species and cut. Natural variations of veneer grain and pattern will vary from these illustrations. These are representative drawings of real wood veneers. Involve your woodworker early in the design and selection process.



VERY BROAD PATTERN
Rotary cut

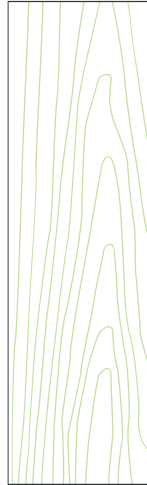

CATHEDRAL PATTERN
Flat cut (plain sliced)

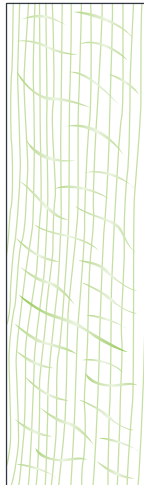

NARROW STRIPED PATTERN (FLAKE)
Quarter cut, red and white oak

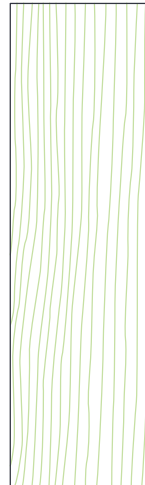

NARROW STRIPED PATTERN
Quarter cut, other species

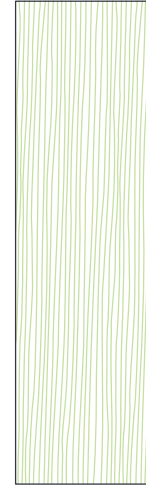

NARROW STRIPED PATTERN
Rift cut, red and white oak

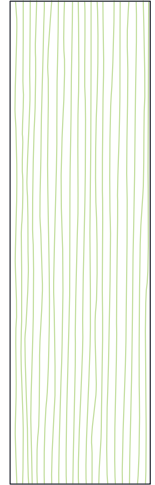

NARROW STRIPED PATTERN
Comb grain, red and white oak only

MATCHING BETWEEN INDIVIDUAL PIECES OF VENEER

The way in which the individual cuts are placed next to each other during the fabrication of the veneer face is the next factor affecting the appearance of the doors. The type of match at the joint line must be specified.

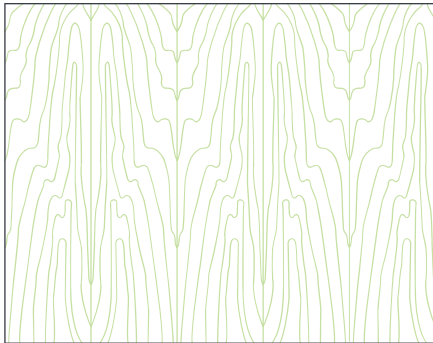

BOOK MATCH
The most commonly used match in the industry. Every other piece of veneer is turned over like adjacent pages in a book. The veneer joints match and create a mirrored image pattern at the joint line, yielding a maximum continuity of grain. Book matching is used with plain sliced, and less often with other cuts of veneers.

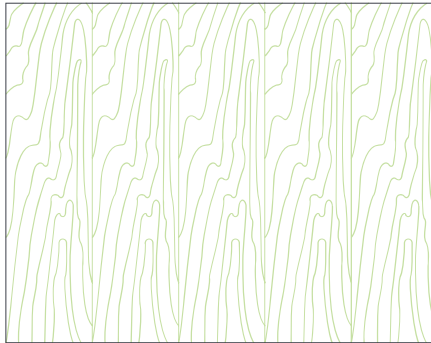

SLIP MATCH
Adjoining pieces of veneer are placed in sequence without turning over every other piece. The grain figure repeats, but joints won't show mirrored effects. Slip matching is often used in quarter cut, rift cut, and comb grain veneers to minimize the barber pole effect.

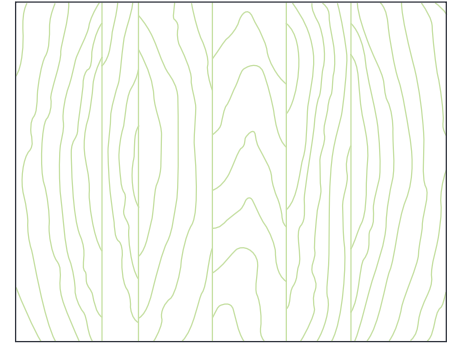

RANDOM MATCH
A random selection of individual pieces of veneer from one or more logs. Produces a "board-like" appearance.

WOOD VENEER SELECTION

(Reference : © 2009, AWI, AWMAC, WI - AWS - 1st Edition, October 1, 2009 and WDMA 1.S.1A-04)

ASSEMBLY OF SPLICED VENEER ON A FACE

The type of "assembly match" must be specified to obtain the desired appearance. Any sequence matching from opening to opening must be specified. The following three face assembly methods give the design professional a wide range of flexibility and cost control.

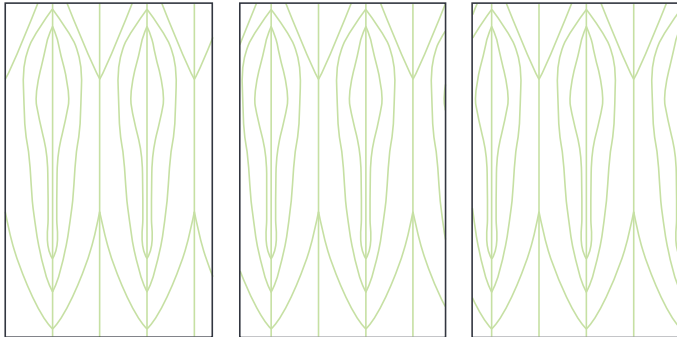

RUNNING MATCH

Veneer pieces of unequal width. Each face is assembled from as many pieces as necessary to cover it.

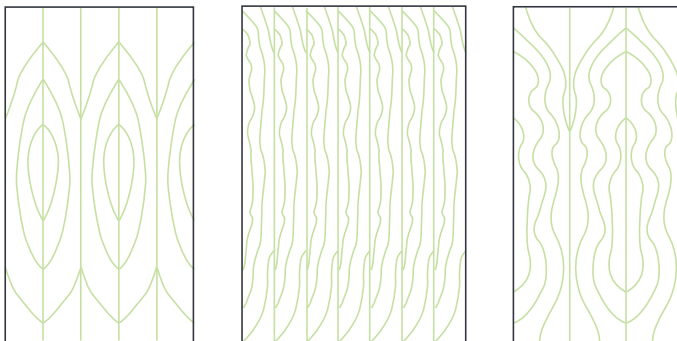

BALANCE MATCH

Each face is assembled from veneer pieces of uniform width.

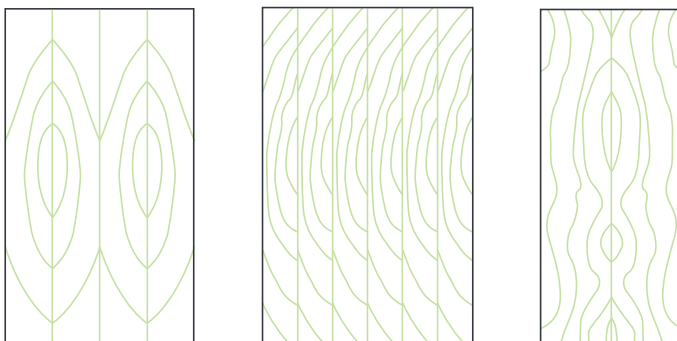

CENTER BALANCE MATCH

Each face is assembled from an even number of veneer pieces of uniform width. A veneer joint in the center of the piece creates the line of symmetry.

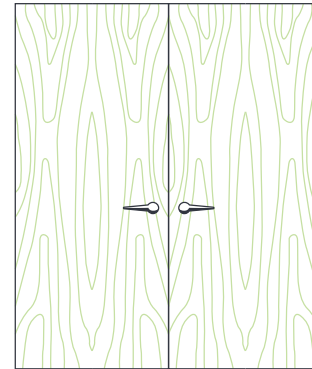

PAIR MATCH

Double doors may be specified as color-matched, pattern-matched or both.

DOORS WITH TRANSOM

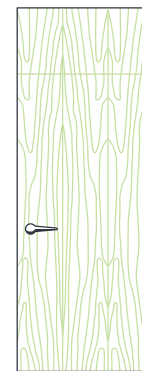

A single piece of veneer extends from the top of the transom to the bottom of the door. Available veneer length in the species may limit this option.

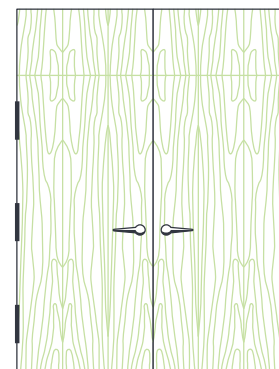

END MATCH

A single piece of veneer extends from the bottom to the top of the door with a mirror image at the transom.

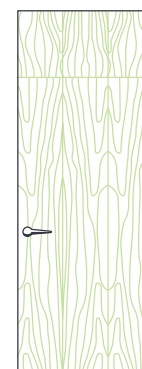

COLOR MATCH ONLY

Each face is assembled from veneer pieces of uniform width.

WOOD VENEER SELECTION

(Reference : © 2005, AWI/AWMAC and WDMA I.S.1A-04)

VENEERS CUTS

The way in which a log is cut in relation to the annual rings determines the appearance of veneer. The beauty of veneer is in the natural variations of texture, grain, figure, color and the way it is assembled on a door face.

FLAT CUT (PLAIN SLICE)

The half-log flitch is mounted flat on the slicer guide; slicing is parallel to a line through the center of the log. A pattern similar to that of flat-sawn wood is obtained. In the flat-cut veneer process, the individual veneer pieces obtained are kept in the order they are sliced, permitting a natural grain progression when assembled as veneer faces.

- | Most common slicing method
- | Veneer cut along the growth rings
- | Frequently results in a familiar combination of "cathedral" and straight grain patterns
- | Because plain slicing offers the highest yield of the slicing methods, it is generally the least expensive

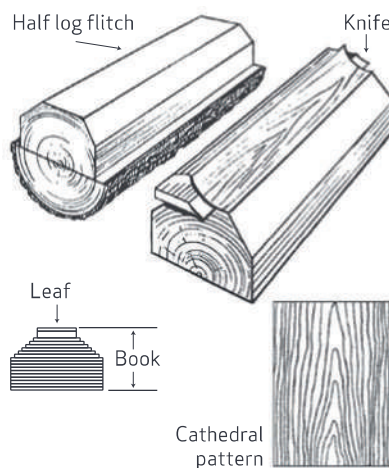

ROTARY

The log is centered on the lathe and turns against an extremely sharp knife which produces the veneer in a thin sheet, as if unrolling a roll of paper. The cut follows the log's annual growth rings, producing a coarse-grained pattern. Veneers obtained by the rotary method are exceptionally wide and matching at the joints is difficult. Almost all softwood veneers are obtained in this way. Hardwood lengths are limited to 10 feet (3 meters).

- | Used in the majority of stock panels produced in North America
- | Produces a broad, variegated pattern
- | Yields the most veneer per log
- | Can produce a limited amount of full-sized whole piece faces
- | Generally, rotary cut veneer is less expensive than sliced veneer

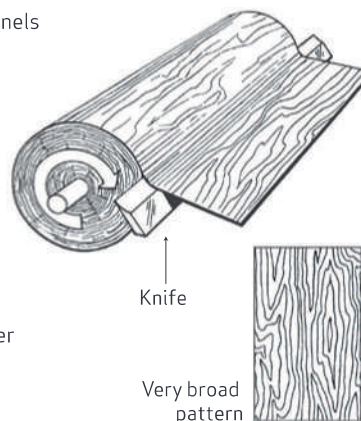

QUARTER CUT

The quarter log flitch is placed on the guide so that the annual growth rings are approximately at a right angle to the knife, to produce a series of stripes, straight in some species, variable in others. In certain wood species, especially oak, a flake pattern is produced when slicing through medullary rays.

- | Cut is perpendicular to the growth rings
- | Produces a straight grain appearance
- | May produce ray flake in red and white oak
- | Produces narrower components than plain slicing
- | Because quarter slicing yields less veneer per log than plain slicing, it is generally more expensive than plain slicing

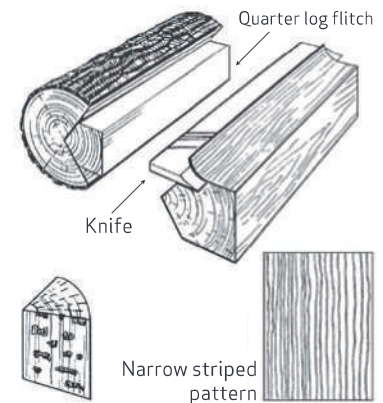

RIFT CUT

Rift cuts are used mainly on various oak species. These species have medullary rays starting at the center of the log like the spokes of a wheel. This veneer is obtained by slicing at a shallow angle across these rays. The process accentuates the vertical grain and minimizes "flake." Comb grain consists of rift-cut veneers distinctive for their tight, straight grain. Comb grain: Limited availability. This is a rift cut veneer distinguished by the tightness and straightness of the grain along the entire length of the veneer. Slight angle in the grain is allowed. Comb grain is restricted to red and white oak. There are occasional cross bars and fleck is minimal.

- | Red and white oak are generally the only species that are rift cut
- | Produces straight grain appearance in oak with minimal flake
- | Produces the narrowest components of the slicing methods
- | Because rift cutting yields the least veneer per log, it is generally the most expensive slicing method

